

Options for Handling Chronic Subclinical Mastitis During Lactation in Modern Dairy Farms

Leitner, G.,^{1*} Koren, O.,² Jacoby, S.,³ Merin, U.³ and Silanikove, N.³

¹ National Mastitis Reference Center, Kimron Veterinary Institute, P.O. Box 12, Bet Dagan 50250, Israel

² Hachaklait Veterinary Services Ltd., Israel

³ Institute of Animal Science and Institute of Technology and Storage of Agricultural Products, A.R.O. The Volcani Center, P.O. Box 6, Bet Dagan 50250, Israel

* Correspondence: Dr. G. Leitner, e-mail: leitnerg@moag.gov.il

ABSTRACT

Subclinical mastitis is the predominant form of mastitis in modern cow herds, and greatly affects dairy economics. The aim of the present study was to exploit available on-line computerized data to suggest a rational procedure that would enable effective treatment of infected udders. The cows were divided into five categories: no intervention, antibiotic treatment, drying-off specific quarter(s) with casein hydrolyzate, drying-off the whole cow and culling. The first step in the analysis was identification of the infected udder and the causative pathogen. The second step was to determine the sensitivity of the pathogen (mostly bacteria) to antibiotic treatment. Of the 62 high somatic cell count (SCC) cows, 40 (64.5%) were cured. The highest cure was achieved in mammary glands infected with *Streptococcus dysgalactiae*, followed by those with *Staphylococcus chromogenes*. No differences were found for the cure of cows in their first to third lactations but were significantly lower in lactations 4 and 5. When treatment was applied within a month from the estimated occurrence of the infection, the success rate was over 73%, whereas treatment after 3 months or more achieved significantly lower success. The average SCC towards the time of antibiotic treatment was about 1.5×10^6 cells mL⁻¹. At first milk testing, about 1 month after treatment, SCC was at a level of about 100,000 cells mL⁻¹ and it remained at that level for the subsequent 3 months. The 17 cows that underwent drying-off of a single infected gland had SCC > 10⁶ cells mL⁻¹ for at least 3 months. Drying off of the secretion from the infected glands reduced the overall SCC to < 200,000 cells mL⁻¹. Milk yield from the uninfected three quarters decreased on average by about 9% during 30 days post-treatment. Treatment options of subclinical mastitis according to the results require early detection, identification of the bacterium and calculation of the economic benefit, taking into account the conditions and the value of the animal to the farmer.

Key words: Mastitis, Treatment, Casein hydrolyzate, Herd management

INTRODUCTION

Economic pressure drives modern dairy farmers to exert continuous efforts to maximize profitability. This is achieved by constant improvement of genetic selection, nutrition, and herd management. Modern dairy farms are characterized by high levels of computerized data acquisition, which provides on-line information on cows' milk yield, milk composition and body weight, and input on cows' behavior, such as

step counts, lying duration, and rumination, all of which help farmers to reach their goals (1). A side effect of modernization is the increase in herd size to hundreds and even thousands of cows (2, 3). One outcome of this trend is the development of a concept that cow herd management and health control should be focused on the herd rather than on the individual cow (4), as in traditional dairy farming. Paradoxically – or apparently so at first glance – the prevalence of on-line

computerized data enables modern farmers to reach decisions on individual cows, even among large herds (1).

Mastitis is the single most important factor that imposes economic burdens on dairy farms worldwide. It is estimated that mastitis infections affected 30% of dairy cattle and cost the EU dairy industry about €1.55 billion in 2005 (5) and the US industry US \$2 billion (6). Subclinical infection results in decreased milk yield, deterioration in milk quality, and increased risk of culling (7, 8), especially owing to its wide prevalence, reaching 20 to 40% of the udders in some herds (5, 9). Many of the cows with subclinical chronic infection are not noticed because there are no recognizable symptoms, and the milk appears normal. Routine monthly milk recording including SCC is a practical procedure in many countries, which could serve as a basis for treatment decisions (10-12). However, the elapsed time between two such tests results in delay of the relevant information for a decision.

On-line computerized milking systems which provide measures of changes in milk yield and conductivity can help in the identification of subclinically infected cows soon after the occurrence of the infection (13). Thus, in addition to the identification of visible clinical mastitis that system provides valuable information on new infection, not visible to the farmer, close to its occurrence, which could help in shortening the elapsed time till treatment.

The decision on whether to treat the cows or to ignore the infection is not simple: antibiotic treatment of cows that are not at risk as in the case of clinical mastitis needs to be justified with respect to the costs of medicine and milk loss (10, 11, 14). The control means that are currently available in the hands of veterinarians and farmers to enable them to handle mastitis during lactation include treatment with antibiotics, segregating the milk obtained from the infected quarter, obliterating the infected gland or culling the cow.

Recently, a new technique based on infusion of casein hydrolyzate (CNH) into treated glands was shown to be effective in drying-off milk secretion from the treated gland. This procedure imitates in an accelerated mode the process induced during mammary gland involution (15-18). In addition to the immediate improvement of milk quality, infusion of CNH forcefully activated the glandular innate immune system, an effect that was reflected in high cure rates of up to 90% (19) and the gland reverts to full activity in the subsequent lactation (15-18).

The aim of the present study was to propose a procedure

that would enable veterinarians and farmers to exploit mastitis-control as close as possible to the occurrence of the infection by on-line computerized data acquisition or in the lesser preferred routine by the monthly test. The limitations of this study were that only one farm was used with a small number of animals. This allowed only outlining the parameters tested as a framework for different farms. The procedures considered were: no intervention, antibiotic treatment, drying-off milk secretion from an infected gland with CNH, drying-off the whole udder or culling.

MATERIALS AND METHODS

Study protocol

All treatments protocols were approved by the Institutional Animal Care Committee of the Agricultural Research Organization.

The study was carried out on a dairy herd of 200 lactating Israeli Holstein cows at the Agricultural Research Organization of the Volcani Center. The dairy parlor was equipped with an on-line computerized AfiFarm Herd Management (S.A.E. Afikim, Israel) data acquisition system that included the AfiLab (S.A.E. Afikim, Israel) milk analyzer, which provided on-line data on milk gross composition (fat, protein and lactose) and milk conductivity (a measure of mastitis) (<http://www.afimilk.com>). The cows were milked three times a day, and the average milk yield (MY) for this farm throughout 2008 was about 10,500 L during 305 days of lactation. Routine monthly milk yield and SCC were recorded by the Israeli Cattle Breeders Association. During the study period the monthly average bulk tank SCC varied between 170,000 to 220,000 cells mL⁻¹. Clinical udder infections were treated with antibiotics according to the herd veterinarian's decision. The daily on-line cow exception report (conductivity, MY and animal behavior) produced by the computerized system and the monthly routine milk recordings served as the basis for the identification of suspected cows. The cows were identified by the on-line computer and cows with SCC > 200,000 cells mL⁻¹ (monthly routine milk recording) were examined by quarter, for bacteriology, CMT and SCC (20).

If a bacterium was isolated accompanied with SCC > 200,000 cells mL⁻¹, an antimicrobial susceptibility test was performed in accordance with NCCLS guidelines (21) by

means of commercially available disks – Dispens-O-Disc (Susceptibility Test System, Difco) or BBL Sensi-Disc Antimicrobial Susceptibility Test Discs (Becton Dickinson, MD, USA) – which were applied as recommended by the manufacturers. The plates were incubated at 30°C for methicillin (5 µg/disk), and at 37°C for other antibiotics: penicillin G (10 units/disk), erythromycin (15 µg/disk), cephalothin (30 µg/disk), neomycin (30 µg/disk), trimethoprim-sulfamethoxazol (1.25-23.75 µg/disk). The results were interpreted in terms of susceptibility or resistance, according to the manufacturers' recommendations. Cows were treated with antibiotics except for cows that had only one quarter with SCC > 10⁶ cells mL⁻¹ for at least three months with or without isolated bacteria. The latter cows and cows that failed the antibiotic treatment underwent quarter drying-off with CNH.

Cows treated with antibiotic were infused with a tube of Nafpenzal MC (180 mg Penicillin G (300,000 I.U.), 100 mg Dihydrostreptomycin, 100 mg Nafcillin) or DC (300 mg Procaine benzylpenicillin (300000 I.U.), 100 mg Dihydrostreptomycin, 100 mg Nafcillin) (Intervet, Boxmeer, The Netherlands) daily for 3 days in all quarters, both infected and uninfected, together with 50 mL of 30 PEN and intramuscularly injected GENTAJECT (ABIC Biological Laboratories, Teva Ltd., Israel). Treatments were carried out after the midday milking and the treated cows were not milked at the evening milking. The milk was discarded for a few days in accordance with the instructions of Delvotest (DSM Food Specialties, Delft, The Netherlands), and was then tested daily for antibiotic residues till complete disappearance of inhibition.

Cows treated with CNH (prepared under Good Manufacturing Practice conditions) (17) received one or two infusions of 10 mL of peptide concentrate of the CNH preparation, at about 7 mg mL⁻¹, into the infected quarter at the midday milking and were not milked at the evening milking. Milk yield per cow was calculated as daily milk yield (MY) at 30 days before treatment and 30 days from the 5th day post-treatment. At the next and subsequent milkings, the remaining untreated quarters were milked normally. Dried-off cows received the routine treatment of the herd, i.e., Nafpenzal DC (17). Food was offered *ad libitum* in managers located in the sheds.

Bacterial cure was defined as the non-appearance of the bacterium and SCC < 150,000 cells mL⁻¹ in milk sampled

from the treated quarter tested monthly for the first 100 days following treatment.

Statistical analysis

All statistical analyses were carried out with JMP software (22). The effects of infection-causing agents (*Streptococcus dysgalactiae*, *Streptococcus uberis*, *Staphylococcus aureus*, *Staphylococcus chromogenes*), lactation number (1-5), time of incidence (1, 2, 3 months) of high SCC (> 200,000 cells mL⁻¹) and days in milk (Days in Milk) (DIM) (< 99, 100-200, > 200 days) on cure were compared separately by means of the chi-squared (χ^2) test. These results were further analyzed for the major effects – causative bacterial infection, lactation number, DIM and time (month) of incidence – with a nominal logistic test.

RESULTS

Overall, 62 cows with high SCC (> 200,000 cells mL⁻¹) and/or identified bacteria (Fig. 1A-D) were treated with antibiotics and the infected quarters of 17 cows were dried-off with CNH. The on-line system identified 22 of the 62 cows most of which had very low SCC (about 30,000 cells mL⁻¹) at the last routine milk recording. All the bacteria tested were found to be sensitive to at least one antibiotic among the drugs used. Of the 62 cows, 40 (64.5%) were cured. The highest cure rate was achieved in mammary glands infected with *Streptococcus dysgalactiae*, followed by those with *Staphylococcus chromogenes*, with 81.8% (18/22) and 69.6% (16/23), respectively (Fig. 1A). Cure in cows infected with *Streptococcus uberis* was lower than 40% (2/5). Interestingly, 4 of the 12 cows without detected causative agent returned to normal milk production with low SCC after treatment. No differences were found among the cure of cows in their first to third lactations – about 70% – whereas in older cows (lactations 4 and 5) the treatment success was significantly lower (25%) (Fig. 1B). No significant difference was found between success of treatment applied at the beginning of the lactation and that applied more than 100 days postpartum, but success in the later days of the lactation were lower (Fig. 1C). When treatment was applied within a month from the estimated occurrence of the infection, the cure rate was over 73%, whereas treatment after 3 months or more achieved significantly lower cure rates (46.9%) (Fig. 1D). Examination of all the above effects showed that causative agents were the

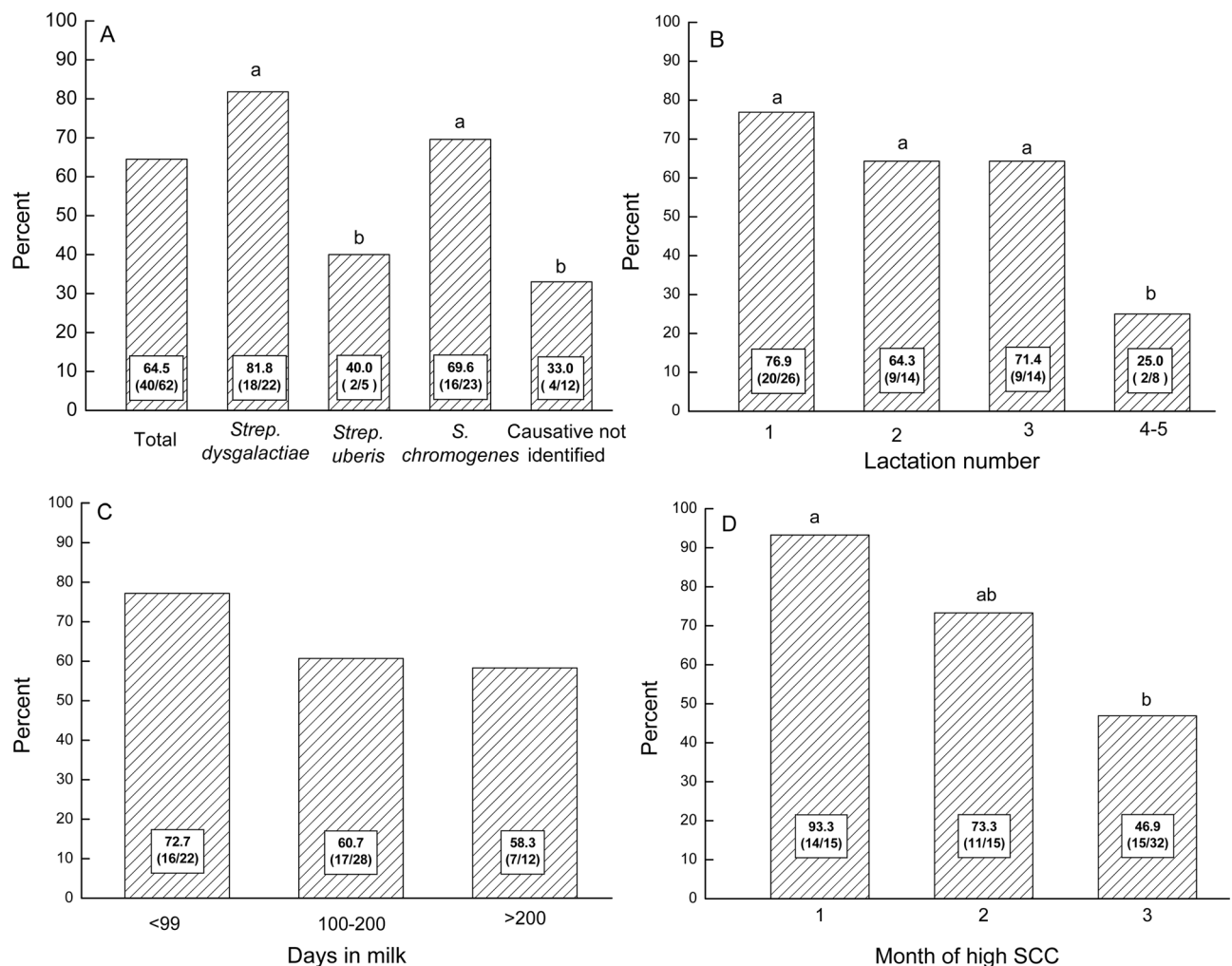

Figure 1. Effects of antibiotic on cure as influenced by: bacterial sensitivity to the antibiotic (Fig. 1A); cow's age (lactation number; Fig. 1B); lactation stage (days in milk; Fig. 1C); and infection persistence (months of high SCC before treatment; Fig. 1D). Letters above bars with no common superscript differ significantly ($P < 0.05$).

major significant effects ($P = 0.027$), followed by the elapsed time between initiation of inflammation symptoms and application of treatment ($P = 0.058$).

Milk yield and SCC of the 40 cured cows are displayed in Fig. 2. The average SCC (Fig. 2A) towards the time of antibiotic treatment was about 1,500,000 cells per mL. At first milk testing, about one month after treatment, SCC was at a normal level (about 100,000 cells mL⁻¹) and it remained at that level for the subsequent 3 months. On average, before treatment, milk yield was 35 kg day⁻¹ (Fig. 2B). At the first milk testing after treatment, milk production increased slightly, and it remained at the new level for up to 3 months, despite the advancing in DIM which typically is associated with reduced MY.

The 17 cows that underwent single quarter drying-off by CNH were in various lactations (1-4), DIM (60-480), empty or pregnant, with MY of 23-55 kg day⁻¹, were infected with various bacteria – *Streptococcus dysgalactiae*, *Streptococcus uberis*, *Staphylococcus aureus*, *Staphylococcus chromogenes*, *E. coli* or no identified causative agent. All the 17 cows had one infected gland with SCC > 10⁶ cells mL⁻¹ for at least 3 months, which forced the farmer to milk the infected glands separately because the other three glands were free of bacteria. Several cows had undergone unsuccessful antibiotic treatment. After treatment the infected glands were not milked, and during the following 5 to 15 days the treated quarters atrophied, with disappearance of pressure, swelling and pain. Figure 3 presents the mean changes in SCC and MY, at the cow level,

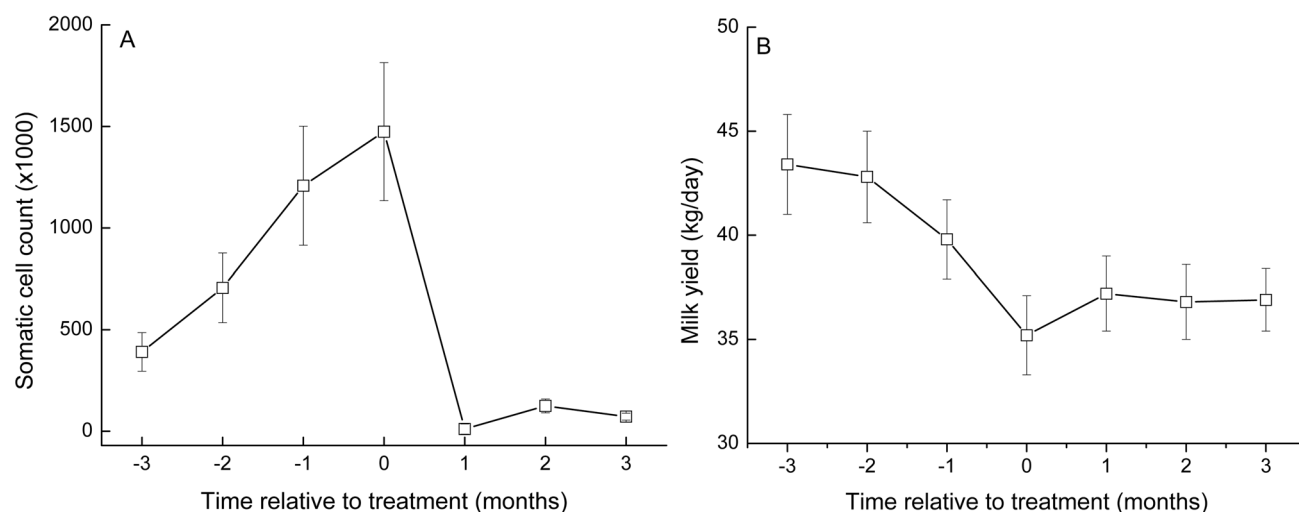

Figure 2. Effects of antibiotic treatment on SCC (Fig. 2A) and milk yield (Fig. 2B), before and after treatment.

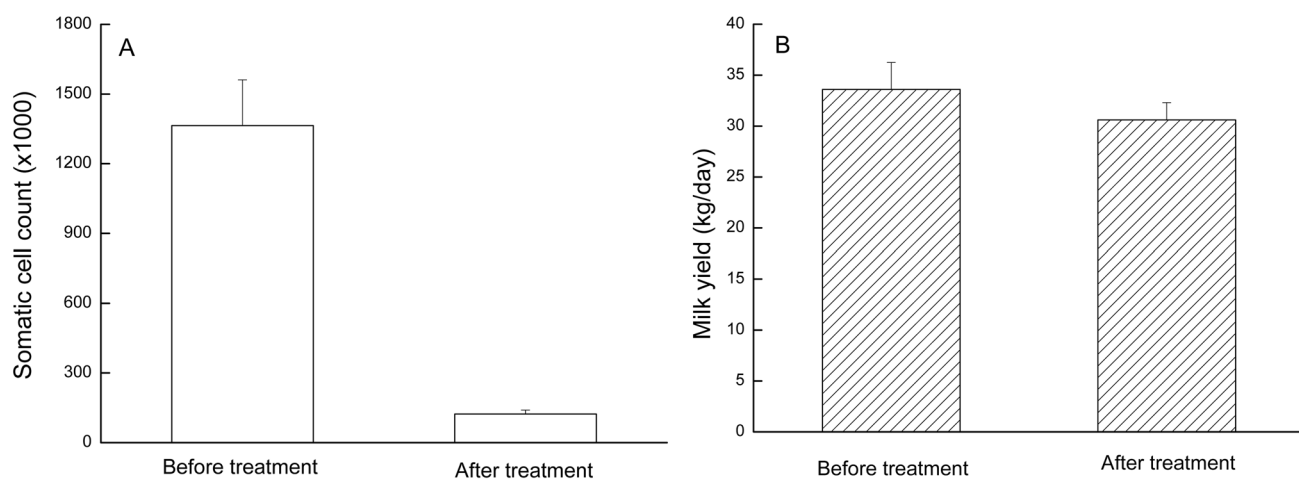

Figure 3. Effects of drying specific quarter with casein hydrolyzate (CNH) on SCC (Fig. 3A) and milk yield (Fig. 3B), before and after treatment. Milk yield per cow was calculated as daily milk yield at 30 days before treatment and 30 days from the 5th day post treatment.

before and after treatment. Drying-off of the secretion from the infected glands and cessation of milking were reflected in reduction of the overall SCC to $< 200,000$ cells mL^{-1} . Milk yield from the uninfected three quarters decreased on average by about 9% during 30 days post-treatment. The largest decrease in milk yield was recorded for cows close to partum, which had high yields, whereas almost unchanged yields were recorded later in the lactation, from cows producing about 30 kg day^{-1} . Eight of the cows treated with CNH had proceeded into their next lactation at the time of closing the study. At drying-off, the cows were treated with antibiotic in the three active glands. All the cows delivered healthy calves,

and in the subsequent lactation, seven of the eight treated glands functioned normally, with no bacteria being isolated. In the udder of one cow which was infected with *E. coli*, the treated gland remained nonfunctional. The SCC during the first 100 days of the subsequent lactation in all the quarters, including the treated glands, was lower than $100,000$ cells mL^{-1} , except for one cow which was re-infected in one of the untreated glands.

By calculating the mean of cow replacement, average milk yield and bulk milk tank SCC during the 3 years before the study and during practicing the outlined procedure resulted in the following: replacement of cows in the herd

was 34.7 ± 3.7 and decreased to 27.9 ± 2.9 (not statistically significant); average milk yield during 305 d was $9,496 \pm 80$ L and increased to $10,445 \pm 25$ L ($P < 0.05$); and bulk SCC was $287,000 \pm 6,000$ and decreased to $192,000 \pm 8,000$ cells mL^{-1} ($P < 0.05$).

DISCUSSION

The aim of the study was to devise a procedural management tool to cope with subclinical mastitis during lactation, utilizing on-line computerized data. The underlying idea was to exploit the on-line computerized data available in modern farms, particularly those related to milk yield, and information related to SCC, e.g., conductivity, etc., in combination with the data gained through the routine monthly testing of individual cows' milk, as described in Materials and Methods (Sec. 2.2.). Then, data on the value of the cow to the owner, such as lactation number, DIM, MY (daily and throughout the lactation) and reproduction status, together with data on the number of infected quarters, time of infection, identities of bacterial isolates and their sensitivity to antibiotics, formed the basis for the treatment decisions by the herd veterinarian and the owner.

The results clearly indicate that without isolation/identification of the agent causing the infection, antibiotic treatment is not justified. This situation is different from that presented in cases of clinical mastitis, where time of treatment is crucial (5), therefore the decision regarding the use of a certain drug depends on the major causative bacteria isolated in the herd at that point of time. In cases of chronic infection, it is crucial to isolate the causative bacterium and to test its sensitivity to any given antibiotic before selecting a treatment. It should be noted that not every isolate means infection. Thus, it was suggested that "true" infection may be regarded as such only if there is an increase in SCC (due to inflammation), and/or a change in the distribution of leukocytes in the milk with or without the isolation of the causative agent (23). Moreover, it is crucial to insure that there is an infection because there are many reports on spontaneous cure of subclinical mastitis, 20-50% (11, 24). Isolation of bacteria without an increase in SCC and/or a change in cell distribution cannot be classified as mastitis, thus repeated culturing is advised (25) and is regarded as the preferred methodology. According to these definitions spontaneous cure found in our previous studied in cows and sheep was $< 5\%$ (26-27).

The present results also indicated that although a bacterium may be found sensitive to the drug in the laboratory, it was not always eliminated *in vivo*, as in the case of *Streptococcus uberis*, and as reported by Barlow *et al.* (10). Thus, it is important to test which drug is suitable for each herd and, if the probability of cure is low as the case in *Staphylococcus uberis*, to take that into account in making the decision.

The second lesson that arises from this study concerns the importance of identifying cows with subclinical mastitis as soon as possible after the bacteria enter the gland. As found in other studies, the longer the duration of infection, the lower is the probability of cure (10, 11, 14). The use of on-line computerized milking devices will help to achieve this task.

The third conclusion is that older cows are more difficult to treat, probably because of more prolonged colonization of the bacteria in the gland tissue, and lower functionality of the immune system (25).

Drying-off a gland with a substance that permanently destroys the gland is an option, although it reduces the value of the cow because of decreased milk yield in the current and subsequent lactations. Nevertheless, this treatment would improve the overall SCC in the bulk milk tank to an extent that would increase the premium quality of the milk, and thereby raise its price. However, with a new drug such as the CNH, which is currently under development as a veterinary drug, a cow can be treated in one or more of the glands during lactation, with minimal milk loss during the treatment (no withdrawal time), improved milk quality and consequently reduced SCC. Milk yield of the remaining glands can increase after treatment due to compensation (28, 29). Moreover, in many cases the CNH treated gland returns to full functionality in the following lactation.

The treatment principles outlined in this study may be used effectively as in a decision-tree analysis (Fig. 4) and as suggested elsewhere (30). Furthermore, as all the recorded data is computerized, a potential future application would be to use a decision-tree analysis as a framework of rules for treatments and to convert these rules into a computerized algorithm that would resolve the problem of the most appropriate treatment decision automatically. Using the suggested treatment options in the studied herd over 3 years clearly indicated that replacements decreased which allowed selling young calves. Owing to the above, older cows remained in the herd and produced higher milk yield. Moreover, the bulk milk SCC decreased despite the latter.

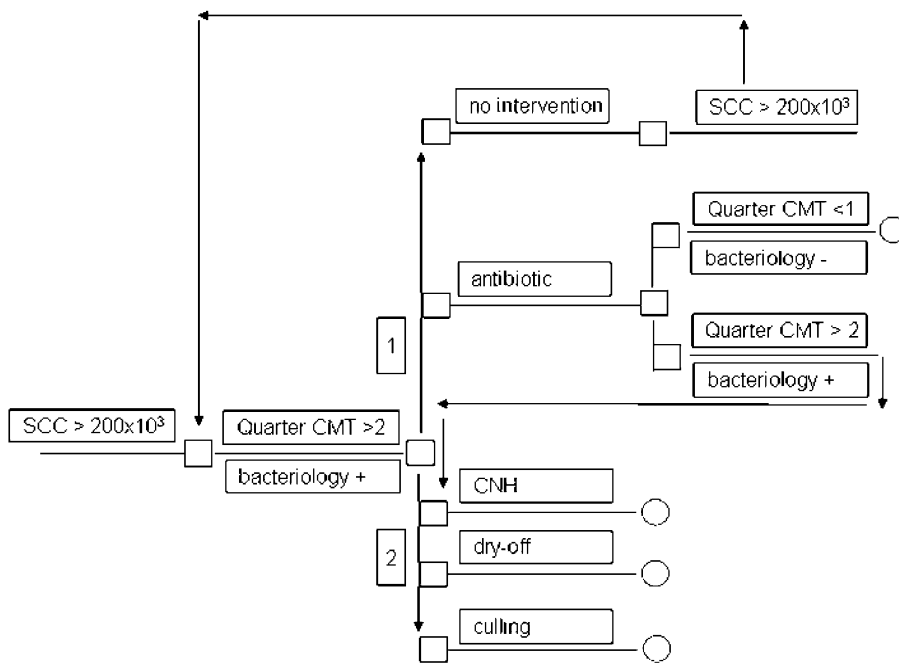

Figure 4. A schematic procedure for applying treatment options in cases of subclinical mastitis. The cows were designated to five categories: a) No intervention; b) Antibiotic treatment; c) Drying-off quarter/s; d) Drying-off whole cow; e) Culling. The first step in the analysis is to identify the infected udder and the causative pathogen. The second step is to determine the sensitivity of the pathogen (usually a bacterium) to antibiotic treatment. The justification for antibiotic treatment would also depend on the cow's age, because older cows will respond poorly to the treatment. An additional important factor is stage of lactation and days in milk – antibiotic treatment is costly because of the treatment cost and milk withdrawal. Thus, cows in late lactation most likely would not cover the cost of treatment by their subsequent output. If the cow does not meet the criteria for antibiotic treatment because of insensitivity of the pathogen, it is possible to dry off the infected quarter. If, however, the cow is in late lactation, her dry-off may be accelerated. If a given cow does not meet all of these criteria, a decision to cull her might be reached.

By taking into account all the considerations evaluated in this study, it is important in any decision making procedure to calculate economic constraints, with regards to parameters such as price of milk and costs of drugs used, including that of the loss of milk during and after the treatment, until the milk is fit for human consumption (30-32). It is important to reemphasize that repeated testing, although expensive, is a minor expense compared to the cost of antibiotic treatment.

Although the results of the study are from a single farm with a small number of cows the routine implementation by exploring the treatment options available for each farm could make this technique of value.

The focus of the present study is the routine implementation of performing an evaluation and reaching a treatment decision according to the monthly milk testing and/or

the constant on-line data available on each cow. With the limitations of the study, it could be concluded that young cows, at the beginning of their lactation and producing high volumes of milk may be expected to cover the costs/losses imposed by the treatment during their productive life. The use of on-line data acquisition was shown to be an effective tool to reach these goals, and the potential availability of CNH in the future will increase the availability of efficient treatments that will be available at the hand of veterinarian and farmers to fight mastitis.

REFERENCES

1. Katz, G., Arazi, A., Pinsky, N., Halachmi, I., Schmilovitz, Z., Aizinbud, E. and Maltz, E.: Current and near term technologies for automated recording of animal data for precision dairy farming. *J. Anim. Sci.* 85:377 (Suppl. 1), 2007.
2. Oleggini, G.H., Ely, L.O. and Smith, J.W.: Effect of region and herd size on dairy herd performance parameters. *J. Dairy Sci.* 84:1044-1050, 2003.
3. Demircan, V. and Binici, T.: Effect of herd size on sustainability of dairy production. *Asian J. Anim. Vet. Advances* 4:60-65, 2009.
4. Nir, O.: What are production diseases, and how do we manage them? *Acta Vet. Scand.* 44:S21-S32 (Suppl. 1), 2003.
5. Hillerton, J.E. and Berry, E.A.: Treating mastitis in the cow - a tradition or an archaism. *J. Appl. Microbiol.* 98:1250-1255, 2005.
6. Losinger, W.C.: Economic impacts of reduced milk production associated with an increase in bulk-tank somatic cell count on US dairies. *J. Am. Vet. Med. Assoc.* 226:1652-1658, 2005.
7. Huijps, K., Lam, T.J.G.M. and Hogeveen, H.: Costs of mastitis: facts and perception. *J. Dairy Res.* 75:113-120, 2008.
8. Leitner, G., Merin, U. and Silanikove, N.: Effects of glandular bacterial infection and stage of lactation on milk clotting parameters: Comparison among cows, goats and sheep. *Int. Dairy J.* 21:279-285, 2011.
9. Pyörälä, S. and Taponen, S.: Coagulase-negative staphylococci - Emerging mastitis pathogens. *Vet. Microbiol.* 134:3-8, 2009.
10. Barlow, J., White, L., Zadoks, R.N. and Schukken, Y.H.: A mathematical model demonstrating indirect and overall effects of lactation therapy targeting subclinical mastitis in dairy herds. *Prevent. Vet. Med.* 90:31-42, 2009.

11. van den Borne, B.H.P., Halasa, T., van Schaik, G., Hogeveen, H. and Nielsen, M.: Bioeconomic modeling of lactational antimicrobial treatment of new bovine subclinical intramammary infections caused by contagious pathogens. *J. Dairy Sci.* 93:4034-4044, 2010.
12. Pyörälä, S.: Treatment of mastitis during lactation. *Irish Vet. J.* 62 (Suppl. 40-44), 2009.
13. Maatje, K., Huijsmans, P.J.M., Rossing, W. and Hogewerf, P.H.: The efficacy of in-line measurement of quarter milk electrical conductivity, milk yield and milk temperature for the detection of clinical and subclinical mastitis. *Livest. Product. Sci.* 30:239-249, 1992.
14. Steeneveld, W., Swinkels, J. and Hogeveen, H.: Stochastic modeling to assess economic effects of treatment of chronic subclinical mastitis caused by *Streptococcus uberis*. *J. Dairy Res.* 74:459-467, 2007.
15. Shamay, A., Shapiro, F., Leitner, G. and Silanikove, N.: Infusions of casein hydrolyzates into the mammary gland disrupt tight junction integrity and induce involution in cows. *J. Dairy Sci.* 86:1250-1258, 2003.
16. Silanikove, N., Shapiro, F., Shamay, A. and Leitner, G.: Role of xanthine oxidase, lactoperoxidase, and NO in the innate immune system of mammary secretion during active involution in dairy cows: manipulation with casein hydrolyzates. *Free Radic. Biol. Med.* 38:1139-1151, 2005.
17. Leitner, G., Jacoby, S., Maltz, E. and Silanikove, N.: Casein hydrolyzate intramammary treatment improves the comfort behavior of cows induced into dry-off. *Livest. Sci.* 110:292-297, 2007.
18. Leitner, G., Jacoby, S. and Silanikove, N.: An evaluation of casein hydrolyzate in combination with antibiotic for bacterial cure and subsequent increase in milk yield in dairy cows. *BMC Vet. Res.* 7:3, 2011.
19. Leitner, G., Krifucks, O., Merin, U., Lavi, Y. and Silanikove, N.: Interactions between bacteria type, proteolysis of casein and physico-chemical properties of bovine milk. *Int. Dairy J.* 16:648-654, 2006.
20. Silanikove, N., Iscovich, J. and Leitner, G.: Therapeutic treatment with casein hydrolyzate eradicates effectively bacterial infection in treated mammary quarters in cows. In: H. Hogeveen, Ed., *Mastitis in Dairy Production: Current Knowledge and Future Solutions*, pp. 327-332. Wageningen Academic Publishers, Wageningen, the Netherlands. 2005.
21. NCCLS: Performance standards for antimicrobial disk and dilution susceptibility tests of bacteria isolates from animals. Approved Standard M31-A, Wayne, PA, USA. 1999.
22. SAS Institute.: *JMP Statistics and Graphics Guide, Version 5*. SAS Institute Inc., Cary, NC, USA. 2000.
23. Leitner, G.: Coagulase-negative Staphylococci species and the dairy industry – significant IMI pathogens. Seminar on Coagulase-Negative Staphylococci in the Bovine. Ghent, Belgium, pp. 23-24, 2010.
24. Taponen, S., Simojokia, H., Haveria, M., Larsen, H.D. and Pyörälä, S.: Clinical characteristics and persistence of bovine mastitis caused by different species of coagulase-negative staphylococci identified with API or AFLP. *Vet. Microbiol.* 115:199-207, 2006.
25. Barkema, H.W., Schukken, Y.H. and Zadoks, R.N.: Invited Review: The role of cow, pathogen, and treatment regimen in the therapeutic success of bovine *Staphylococcus aureus* mastitis. *J. Dairy Sci.* 89:1877-1895, 2006.
26. Chaffer, M., Leitner, G., Winkler, M., Glickman, A., Krifucks, O., Ezra, E. and Saran, A.: Coagulase-negative staphylococci and mammary gland infections in cows. *J. Vet. Med. B* 46:707-712, 1999.
27. Shwimmer, A., Kenigswald, G., Lavi, Y., Merin, U., Weisblit, L. and Leitner, G.: Dry-off treatment in Assaf sheep: efficacy as a management tool for improving milk quantity and quality. *Small Rumin. Res.* 74:45-51, 2008.
28. Hamann, J. and Reichmuth, J.: Compensatory milk production within the bovine udder: effects of short-term non-milking of single quarters. *J. Dairy Res.* 57:17-22, 1990.
29. Hortet, P. and Seegers, H.: Loss in milk yield and related composition changes resulting from clinical mastitis in dairy cows. *Prevent. Vet. Med.* 37:1-20, 1998.
30. Pinzón-Sánchez, C., Cabrera, V.E. and Ruegg, P.L.: Decision tree analysis of treatment strategies for mild and moderate cases of clinical mastitis occurring in early lactation. *J. Dairy Sci.* 94:1873-1892, 2011.
31. Steeneveld, W., van Werven, T., Barkema, H.W. and Hogeveen, H.: Cow-specific treatment of clinical mastitis: An economic approach. *J. Dairy Sci.* 94 174-188, 2011.
32. van den Borne, B.H.P., van Schaik, G., Lam, T.J.G.M. and Nielsen, M.: Therapeutic effects of antimicrobial treatment during lactation of recently acquired bovine subclinical mastitis: Two linked randomized field trials. *J. Dairy Sci.* 93:218-233, 2010.